

To: \_\_\_\_\_

## Specification Document

### Color-changing Recovery Type Water Leakage Sensor AD-RS

Date : (                    )

<Manufacturer >

System Equipment Division  
Electronic Materials & System Equipment Group  
TATSUTA Electric Wire & Cable Co., Ltd.

System Equipment Division		
Approved by:	Checked by:	Prepared by:

## <<<Important safety instructions>>>

### **Warning**

Improper handling of the sensor in non-compliance to any of the following warning precautions or instructions given on a WARNING label can result in death, serious injury, fire, electric shock, and/or sensor failure.

#### Warning Precautions

##### Strictly Prohibited !

- Never use the sensor as electric cable.

##### Confirm !

- The sensor length must not exceed 100 m per circuit.
- Handle the sensor carefully; it will not work if soiled or damaged.
- Take precautions to ensure the sensor does not become wet.
- Before use, be sure to read the precautions on the rear of the sensor case.

##### Caution on Installation !

- Do not install the sensor directly on any surface where dew can form.
- Attach the sensor as tightly as possible to the mounting surface. Any unavoidable gap such as on an uneven floor or the like horizontal surface must not exceed 2 mm, and on a pillar, beam or the like vertical surface the gap must not exceed 1 mm.
- To minimize the influence of external electromagnetic induction, the sensor comprises two electrodes twisted in a braid form. However, avoid installing the sensor over a long distance in parallel with a power cable or other electromagnetic induction sources.
- Where the sensor intersects a power cable of 300 V or higher service voltage, surround the sensor completely with an insulating protective barrier, such as plastic molding.
- Install the sensor so that it can be easily replaced. After detection of water leakage, the sensor is reset when the water has evaporated. However, if the sensor absorbs water that contains conductive or water-repellent material, it possibly cannot be reset and needs to be replaced.
- To prevent electrical corrosion of the sensor, be sure to connect it to an alternate-current water leakage detector.
- Do not allow wax or other oil-based material on the sensor; water is repelled from the surface and may not be detected.

## Table of contents

	Page
1. Scope .....	1
2. Construction .....	1
3. Specifications .....	2

## 1. Scope of Application

The specification document is applicable to the color-changing recovery type water leakage sensor (AD-RS). This sensor can rapidly detect water leakage, and becomes red when absorbing water and restores if dried.

## 2. Construction

Fig. 1 and Fig. 2 show the construction of the AD-RS sensor

Electrode: 0.33 mm<sup>2</sup> tinned annealed copper wire

Inner sheathing: Polyethylene

Outer sheathing: Polyester

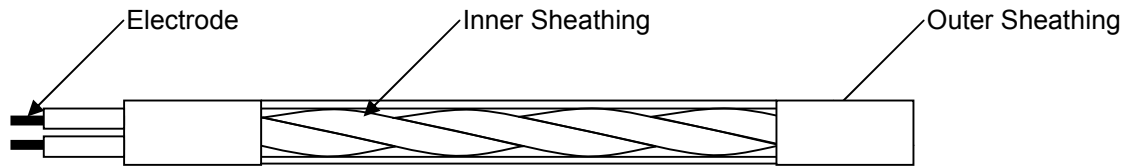

Fig.1: Schematic Diagram of the AD-RS Sensor

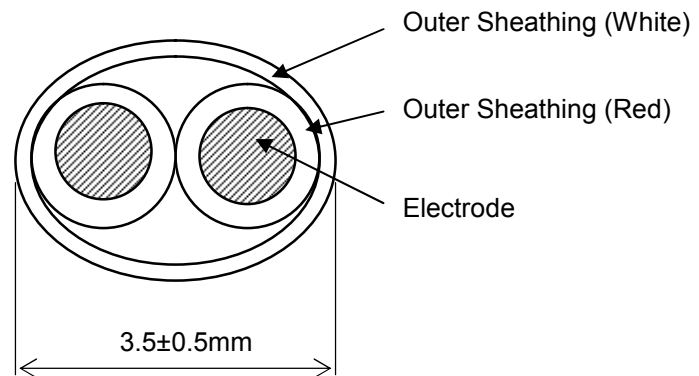

Fig. 2: Cross-section Diagram of the AD-RS Sensor

### 3. Specifications

Table 1 shows the specifications of AD-RS sensor.

Table 1. Specifications

Item	Specifications
Construction	Material: Strand of tinned annealed copper wires Composition: Copper wire 0.18mm in diameter × 13 (0.33 mm <sup>2</sup> )
Detection characteristic	The resistance between electrodes is 5kΩ max. (AC) when the water absorbing (tap water) capacity is 3.0 ml or below. <ul style="list-style-type: none"> <li>• Water dropping amount: directly drop to the sensor (0.05ml/s)</li> <li>• Measuring ambient temperature: 24°C, humidity: 60%RH</li> <li>• Conductivity water temperature: 24°C, 200μS/cm [5.0kΩ·cm]</li> <li>• Testing equipment: Water leakage detector AD-AS-10DRM manufactured by our company.</li> </ul> <p>※ The resistance between electrodes and the amount of water during the sensor operation are dependent on the laying status, environment and water quality for the sensor.</p>
Resetting characteristic	After the water leakage detection, the sensor is reset by natural drying or moisture removal. However, if there are conductive or water-repellent substances in the leaking water, the sensor cannot be reused.
Resistance between electrodes (AC)	10 MΩ min. /100m (measuring ambient temperature: 24°C, humidity: 60%RH)
Humidity resistance	In the high humidity condition, the resistance between electrodes is 100kΩ or above /100m (measuring ambient temperature: 60°C, humidity: 95%RH) provided that there is no moisture condensation.
Heat resistance	60°C max. for continuous operation (heat-resistant temperature: 80°C)
Weight	10.5±1.0 g/m