

To: _____

Specification Document

High Precision Water Leakage Detector AD-AS-1C-SR

Date ()

<Manufacturer >

System Equipment Division
Electronic Materials & System Equipment Group
TATSUTA Electric Wire & Cable Co., Ltd.

System Equipment Division		
Approved by:	Checked by:	Prepared by:

<<< Important Safety Instructions >>>

**Warning**

Erroneous operation of this water leakage detector not complying with the warning labels or the following warnings may lead to fatal accident, serious injury, electric shock, fire, or detector failure.

**Warnings****Strict Prohibitions!**

- Never modify or disassemble the detector.
 - Allow only persons responsible for handling this product to perform installation work on it or to adjust or inspect it with the outer cover opened.
 - Observe ratings of power supply voltage and contact capacity.
 - After the detector is installed, do not leave it with the cover open, except for inspection and maintenance purposes.
 - Do not touch any internal component with wet hands.
 - When performing maintenance on the product, avoid using organic solvent. Use gauze or soft cotton wastes, diluted neutral detergent for gentle wiping.
- Note) Pay attention not to leave any residual cleaning solution on the sensor.

**Checkpoints!**

- Check detector supply voltage and rated voltage before installing.
- When installing and electrically connecting the detector, follow the instructions in the instruction manual.
- When inspecting and maintaining the detector, follow the instructions in the instruction manual.
- To prevent the electrical erosion of sensor, make sure to use an AC water leakage detector.

**Do not install the detector in the following locations!**

- Locations easily accessible to the general public.
- Locations close to sources of vibration, organic gas or strong electromagnetic induction.
- Locations with much waste and dust.
- Locations where there is possibility of water leakage and temperature and humidity are high.

Table of contents

	Page
1. Scope of application	1
2. Overview of Detector	1
3. Advantages and Functions	1
4. Specifications	2
4-1 Use conditions	2
4-2 Ratings	2
4-3 Performance	3
4-4 Control Output Contact Specifications	3
4. Operation Chart	4
◇ Attached Drawing 1: Outside Dimensions of Water Leakage Detector (AD-AS-1C-SR)	

1. Scope of Application

The specification document is applicable for the high precision water leakage detector, Model AD-AS-1C-SR.

2. Overview of the Detector

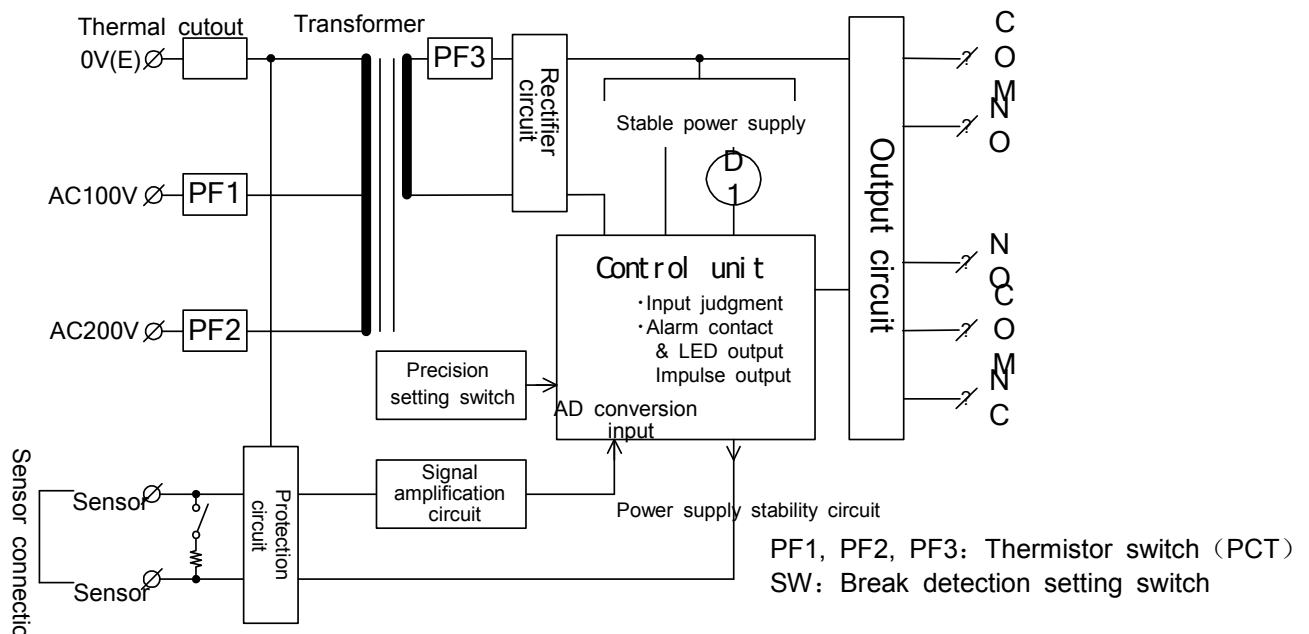

Fig.1 Detector Configuration

3. Advantages and Functions

- (1) RoHS compliant
- (2) The control output contact is the fail-safe output ... Refer to 5. Operation Chart –Fig. 2
- (3) Corresponding instant power-off of the power supply: 141mS
 ... From power OFF to the control output contact variation: 300mS±20%
- (4) There are two forms for the corresponding break detection functions: activated and deactivated... They can be set by the switch on the printed circuit board (factory default setting as “activated”)
- (5) Containing the electrostatic protection circuit for the sensor terminal
 ... The bearing capacity is 15kV or above (contact discharge)

4. Specifications

4-1 Use Conditions

- (1) When the break detection functions are applied, it is necessary to have the break detection terminal (ZT-SR)
- (2) Connectable sensor: AD-FH, AD-S, AD-RS (however, it shall be within the length allowed in the setting environment) and AD-PA-N.
 - As it is a high sensitivity detector, the applied length is limited according to the setting environment of the sensor.
 Please inspect the conductivity, setting environment and atmospheric conditions for the detection liquid.

4-2. Ratings

See Table 1 for the ratings.

Table 1 Ratings

Item	Specifications
Rated voltage	AC100/200V $\pm 10\%$ (for 50/60 Hz)
Power consumption	2VA max.
Control output contacts	*Check Subsection 4-4, Control Output Contact Specifications.
Sensor applied voltage	AC 2.8V max.
Working ambient temperature	-10°C to 50°C (no icing)
Working ambient humidity	35%RH to 85%RH (no condensation)

4-3. Performance

Refer to Table 2 for performance parameters.

Table 2 Performance

Item	Specifications		
Number of sensor circuits	1 circuit		
Set sensitivity	L (0.5M Ω)	M (1.0M Ω)	H (2.0M Ω)
Water leakage detection level	0.5 M Ω ±20%	1.0 M Ω ±20%	2.0 M Ω ±20%
Water leakage recovery level	0.75 M Ω ±20%	1.5 M Ω ±20%	3.0 M Ω ±20%
	* The level values above mentioned specify the resistance between the sensor terminal blocks. When the break detection function is set "activated", the break detection terminal (2.0 M Ω resistance) shall be installed on the sensor When the break detection function is set "deactivated", the sensor terminal shall be in the open state.		
Break detection level	3.3 M Ω ±20% (when the break detection function is set "activated")		
Break recovery level	2.5 M Ω ±20% (when the break detection function is set "activated")		
Power/contact delay	Power ON/control output contact variation: 120mS or below Power ON/control output contact variation: 300mS±20%		
Surface operator panel LED indication	Power indicator lamp: Switched on Water leakage alarm indicator: Flash-1, way of flash: Alternating between on for 0.4s and off for 0.1s. Break alarm indicator: Flash-2, way of flash: Alternating between on for 0.2s and off for 0.1s, as well as between on for 0.2s and off for 0.5s. (Note) The power indicator and alarm (water leakage/break) indicator adopt LED (orange).		
Control output contacts configuration	Contact on	(*Check Subsection 4-4, Control Output Contact Specifications.) Alarm (water leakage/break): 1x1point and 1cx1 point	
Withstand voltage	Power supply terminals ~ control output grounding terminals: AC 1,000 V (50/60 Hz)/1 min.		
Insulation resistance	Power supply terminals ~ control output grounding terminals: over 10 M Ω (with DC 500V Megger) /1 min		
Noiseproof property	±1000V Pulse width: 1 μ SEC (noise simulator)/1 minute (between each phase and the grounding terminal) Static charge: ±10 kV applied through a series combination of a 150PF capacitor and a 330 Ω resistor, with results of no break down and no malfunction (Contact discharge to sensor terminals)		
Outside dimensions	W 45 x H 72 x D 67 ±1mm (see Attached Drawing 1)		
Weight and color	Approx. 115 ±10g, grey		

4-4 Control Output Contact Specifications

Refer to Table 3 for control output contacts.

Table 3 Control Output Contact Specifications

Item	Resistive load
Rated load	AC125V 0.5A
	Dc30V 2.0A

(Relay contacts: G6S-2F-US Catalogue values by Omron Corporation)

5. Operation Chart

Refer to Fig. 2 for the operation chart.

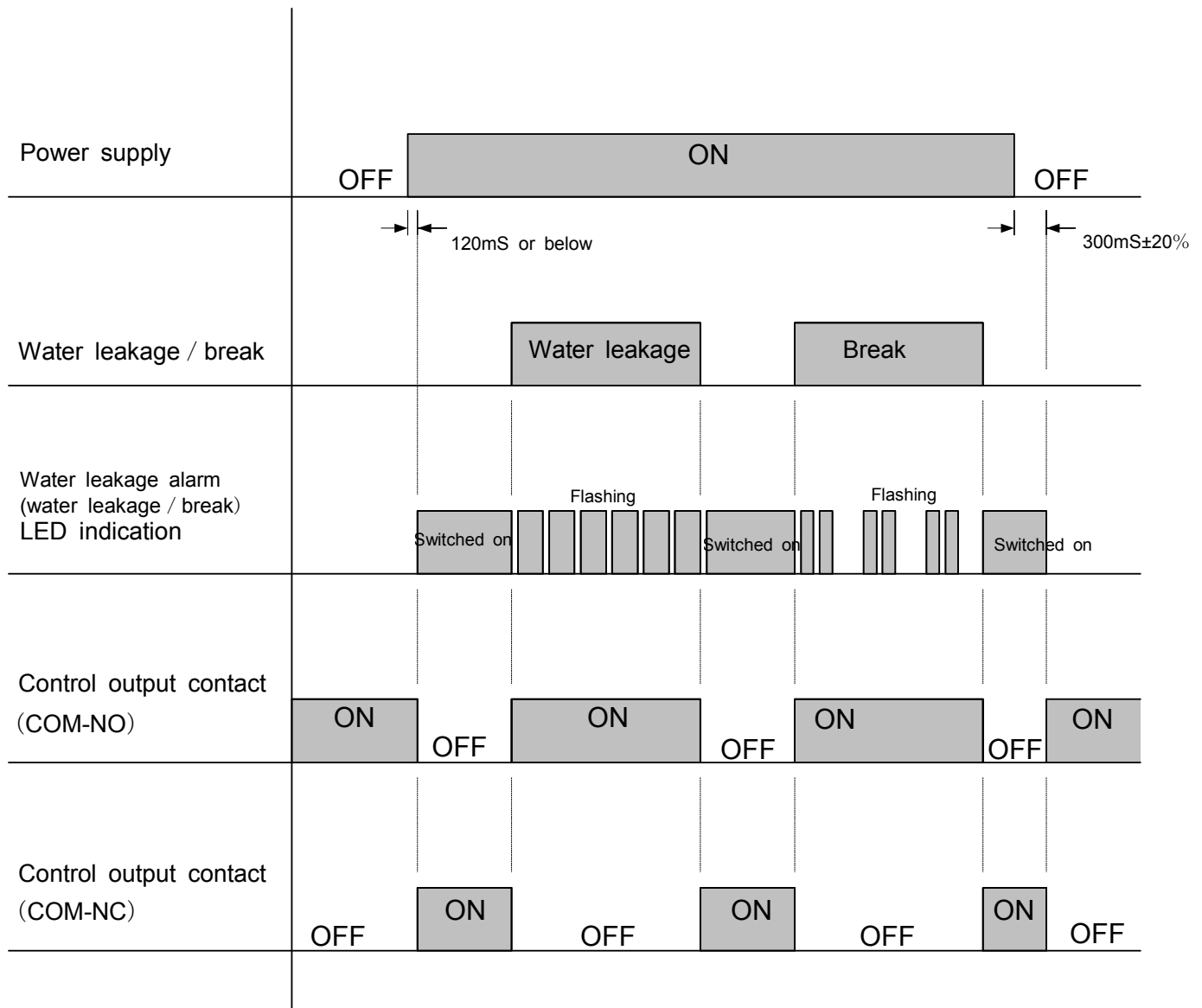
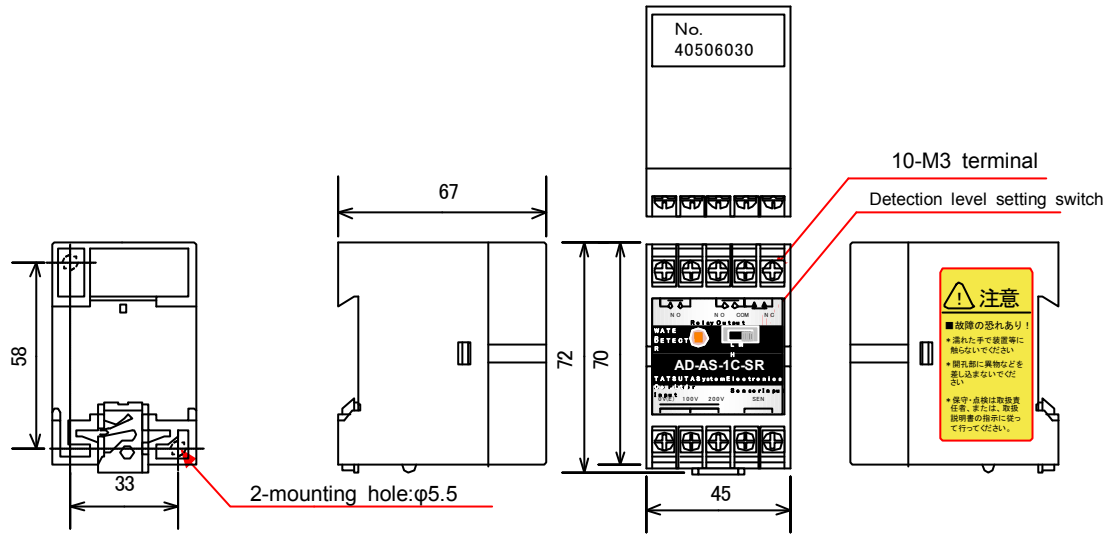

Fig. 2 Operation Chart

(Note) (1) As affected by the humidity and other factors, the sensor is switched when the resistance drops and it is in the state of water leakage detection alarm. Sometimes such state will continue. In such case, water on the sensor shall be completely wiped off before use.

Attached Drawing 1



Approved by	Checked by	Prepared by	Scale	- / -	Name
			Unit	mm	
			Drawn by	2010.04	
TATSUTA Electric Wire & Cable Co., Lt					Drawing No

Outside Dimensions of
Water Leakage Detector
(AD-AS-1C-SR)

TTS-KS-W3132-2